

# BATERIA SELLADA AGM 12V 3.5AH

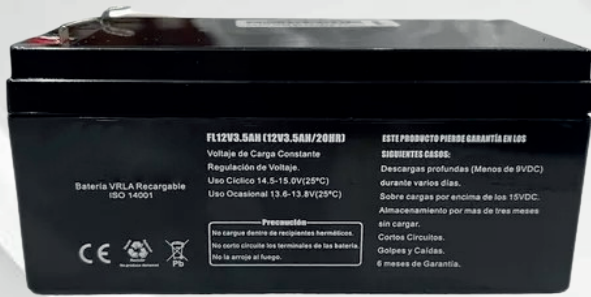

Esta batería está diseñada para ofrecer 5 años libres de mantenimiento según el diseño de su vida útil. Diseñada para aplicaciones como seguridad, sistemas de alarma y CCTV, sistemas de UPS, sistemas de alumbrado de emergencia y otras aplicaciones de respaldo.

## DIMENSIONES

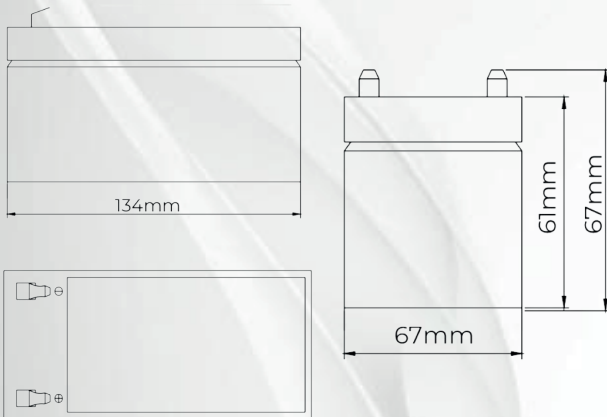

## TERMINAL

### TERMINAL F1

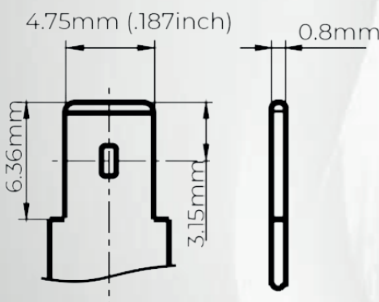

## CARACTERÍSTICAS

Especificaciones Tecnicas	
Voltaje Nominal (V)	12V (6 celdas por unidad)
Diseño Vida Flotación (20°C)	5 Años
Capacidad Nominal (25°C)	3.5 Ah @ 20HR (1.75V pc)
Dimensiones (mm)(LxWxH)	134x67x67
Peso Aproximado (kg)	1.25 kg
Tipo de Terminal	Terminal F1
Resistencia Interna	Aprox 0.035 Ohm
Corriente Max Carga	0.96 A
Corriente Max Descarga (5s)	51 A
Corriente Corto Circuito	340 A
Auto Descarga	Aprox 3% por mes @ 20°C
Temperatura Ambiente	Descarga: -15~50°C Carga: -15~40°C Almacenaje: -15~40°C
Voltaje Carga Flotación (20~25°C)	13.6-13.8V (-3mV/celda/°C)
Ecuilibración	14.4-14.8V (-5mV/celda/°C)
Material	ABS (UL94-V0)

## Características descarga constante corriente

F.V/Time	5min	10min	15min	30min	1h	2h	3h	4h	5h	10h	20h
9.60V	12.2	7.68	6.08	3.39	2.08	1.14	0.82	0.65	0.55	0.30	0.16
9.90V	11.8	7.45	5.93	3.32	2.05	1.13	0.81	0.65	0.55	0.30	0.16
10.2V	11.3	7.14	5.72	3.22	2.00	1.12	0.81	0.64	0.55	0.30	0.16
10.5V	10.8	6.84	5.52	3.14	1.96	1.10	0.80	0.64	0.54	0.30	0.16
10.8V	10.2	6.45	5.23	3.03	1.90	1.08	0.78	0.62	0.53	0.29	0.15

## Características descarga constante potencia

F.V/Time	5min	10min	15min	30min	1h	2h	3h	4h	5h	10h	20h
9.60V	136	86.6	69.3	38.9	24.1	13.3	9.69	7.77	6.63	3.62	1.95
9.90V	132	84.0	67.6	38.1	23.7	13.2	9.64	7.73	6.59	3.61	1.94
10.2V	126	80.6	65.2	36.9	23.1	13.1	9.57	7.68	6.54	3.59	1.93
10.5V	121	77.1	62.9	36.0	22.7	12.9	9.50	7.62	6.50	3.57	1.92
10.8V	114	72.8	59.6	34.7	22.0	12.6	9.22	7.39	6.30	3.50	1.88